

# How to set up **HIRE 6**: LUCAS Performer



# Hire 6: LUCAS Performer

## Unpacking...

All our active speaker systems are protected by transit covers. This is to ensure they stay in good condition ready for you to use at your event.....and of course for the next person and so on 😊



You should have: 1 x LUCAS Performer, 2 x Speaker Leads, 1 x Mains lead, 2 x Speaker Stands and 1 x Carry Bag

# Hire 78: UB502 Sound Desk (ipod / laptop interface)

For use with Hire 6: LUCAS Performer



You should have: 1 x UB502 c/w power lead, 1 x **YELLOW** to **RED** lead (pair), 1 x ipod lead and carry case.

# HIRE 6: LUCAS Performer Sub / Amp

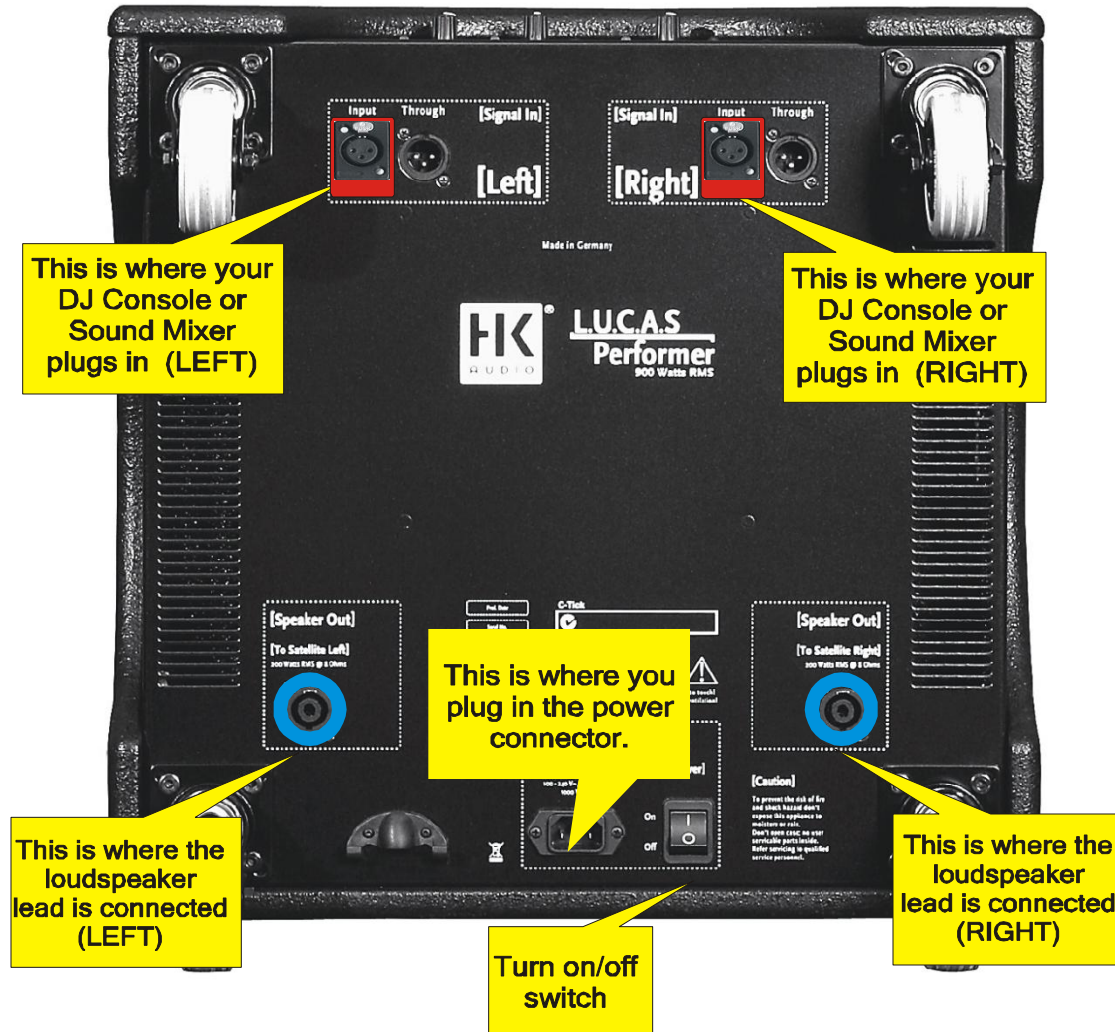

This is where your DJ Console or Sound Mixer plugs in (LEFT)

This is where your DJ Console or Sound Mixer plugs in (RIGHT)

This is where you plug in the power connector.

This is where the loudspeaker lead is connected (LEFT)

This is where the loudspeaker lead is connected (RIGHT)

# LUCAS Performer Satellite Speakers



# LUCAS Performer Speaker Stands



NOTE: 😊

Adjust both sets of legs on the stands to the same distance apart. This ensures they're the same height...

Loosen lower thumb bolt and spread the legs wide enough for your foot to fit under the centre section.

# LUCAS Performer Speaker Stands



Raise inner tube to approx shoulder height. Insert the support pin through one of the holes. Then gently tighten thumb bolt.

# LUCAS Performer

Positioning and fitting satellite speakers onto speaker stands.

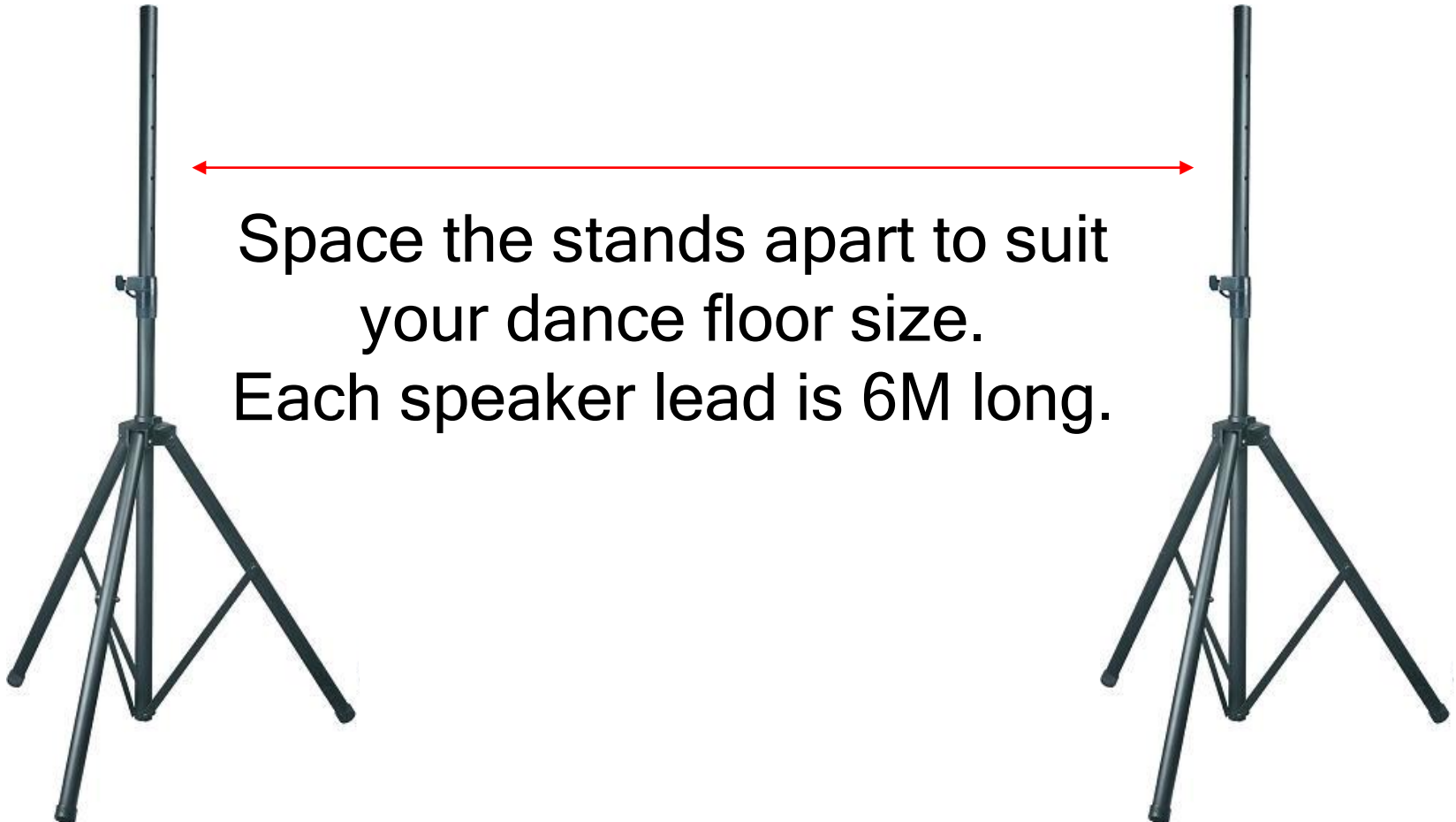

# LUCAS Performer

Positioning and fitting satellite speakers onto speaker stands.



On the bottom of each speaker there is a mounting hole, just lower each speaker onto the top of each stand...done..!

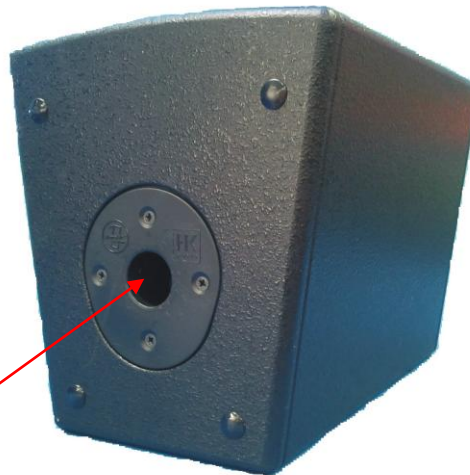

# LUCAS Performer

## Positioning the sub / amplifier

The best place to position the sub / amplifier is central to the satellite speakers, preferably under a table away from spilt drinks etc...

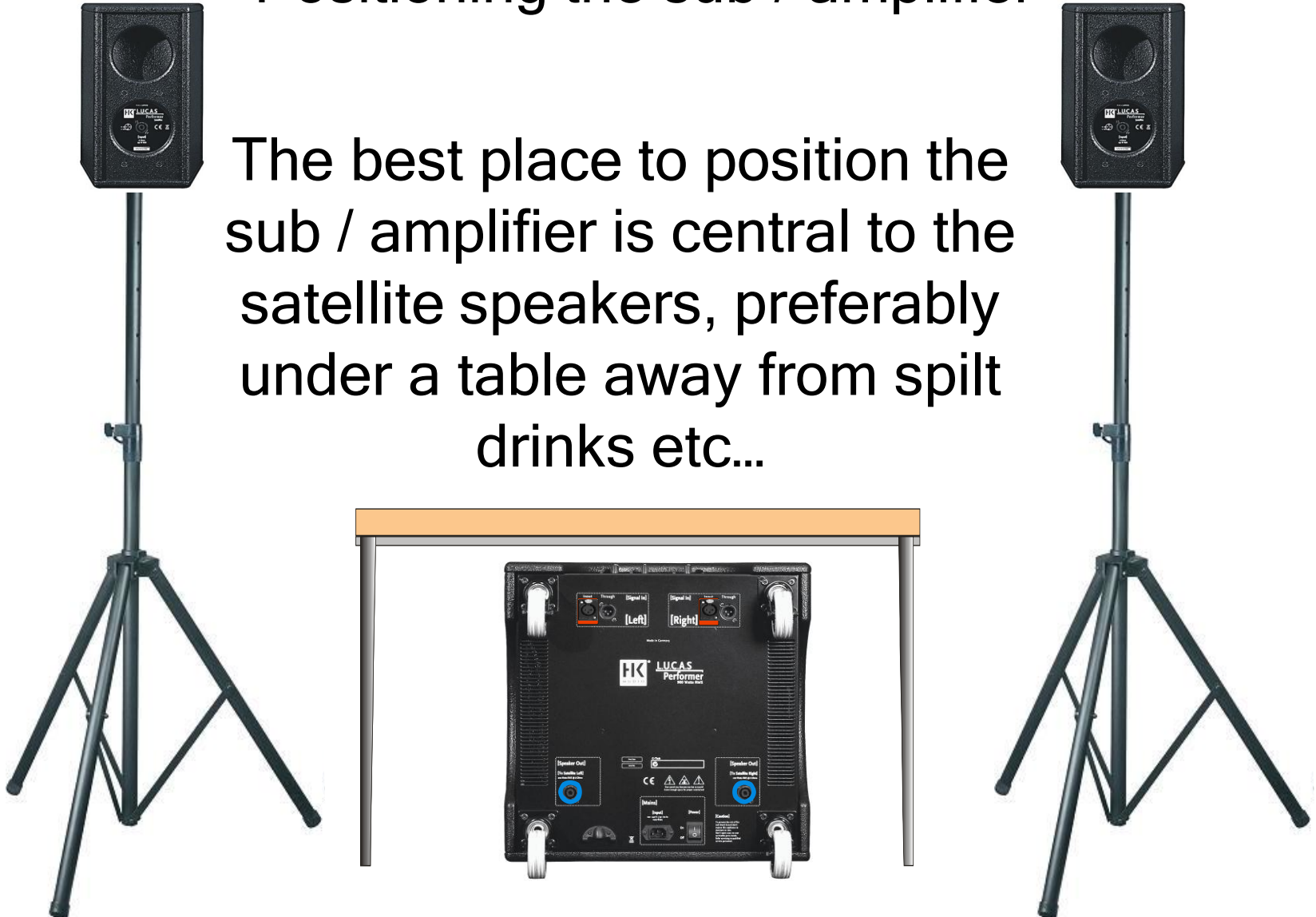

# LUCAS Performer

## Connecting satellite speakers to the sub / amplifier

Once the satellite speakers are on the stands you're ready to connect them to the sub / amplifier.

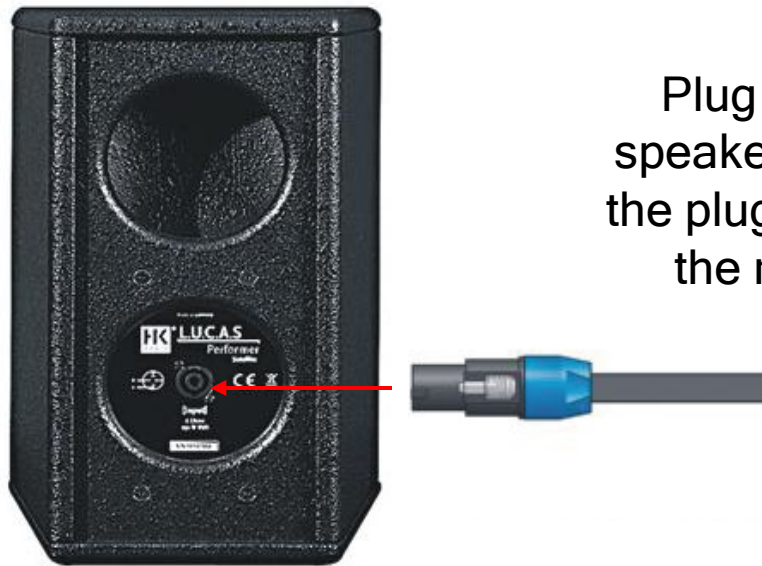

Plug each speaker lead into each satellite speaker. To do this you line up the locators on the plug to the socket, insert and gently twist to the right. You will hear a click to confirm.

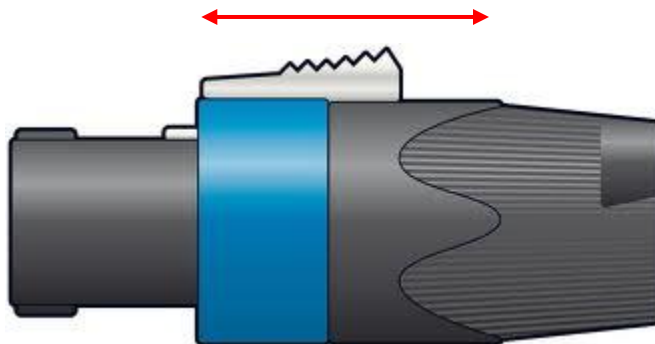

To remove the plug, pull back the metal thumb slide on the plug and twist to the left.

# LUCAS Performer

## Connecting satellite speakers to the sub / amplifier



After each speaker lead is connected to each satellite you simply connect the other end into the speaker socket on each side of the sub / amplifier. This is done the same way as the satellites....easy..!

The sockets are indicated in blue.



# LUCAS Performer

Connecting the interface to the sub / amplifier.



**BEFORE YOU CARRY OUT INSTRUCTIONS BELOW ENSURE THE SUB / AMPLIFIER IS SWITCHED OFF..!**

Make sure that the ipod and cd volume controls are off and that the, “BAL” control is set to 12 o’clock. Make sure the main, “VOL” is off too.

# LUCAS Performer

Connecting your ipod to our interface.



Connect your ipod to our interface. We supply a lead to plug into your headphone socket which in turn plugs into the two sockets in the ipod section. Switch on your ipod, check that the sound settings are set to "FLAT". Press play, increase the volume on the ipod to  $\frac{3}{4}$  level....thats it for now...

# LUCAS Performer

Connecting the interface to the sub / amplifier.



Plug in the mains plug to your power socket, the lead is glued into the interface.

A **Blue** power on indicator will light to confirm its on.

We supply a pair of leads which are colour coded, **YELLOW** one end & **RED** the other.

The two yellow plugs connect to the two sockets marked, "MAIN OUT".

# LUCAS Performer

Connecting the interface to the sub / amplifier.



This is where you should be now....ipod connected, turned on and playing.  
The interface plugged in and turned on too, **YELLOW** to **RED** leads connected at the  
**YELLOW** end...

# LUCAS Performer

## Connecting the interface to the sub / amplifier.

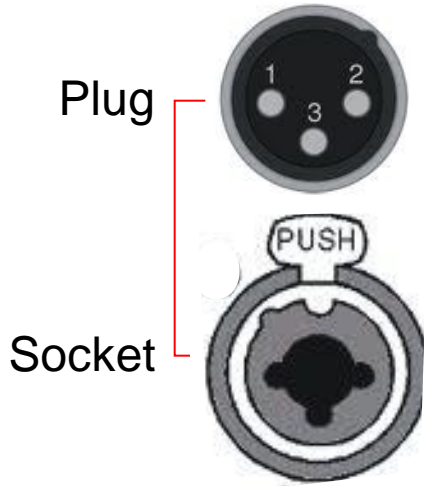

To connect the **RED** plugs into the input sockets you just need to line up the three pins in the plug so that two pins are at the top and one at the bottom. Gently push the plug into the socket... you'll hear a click to confirm.

To release the plug simply push the lug on the socket marked, "**PUSH**" whilst gently pulling back on the plug..

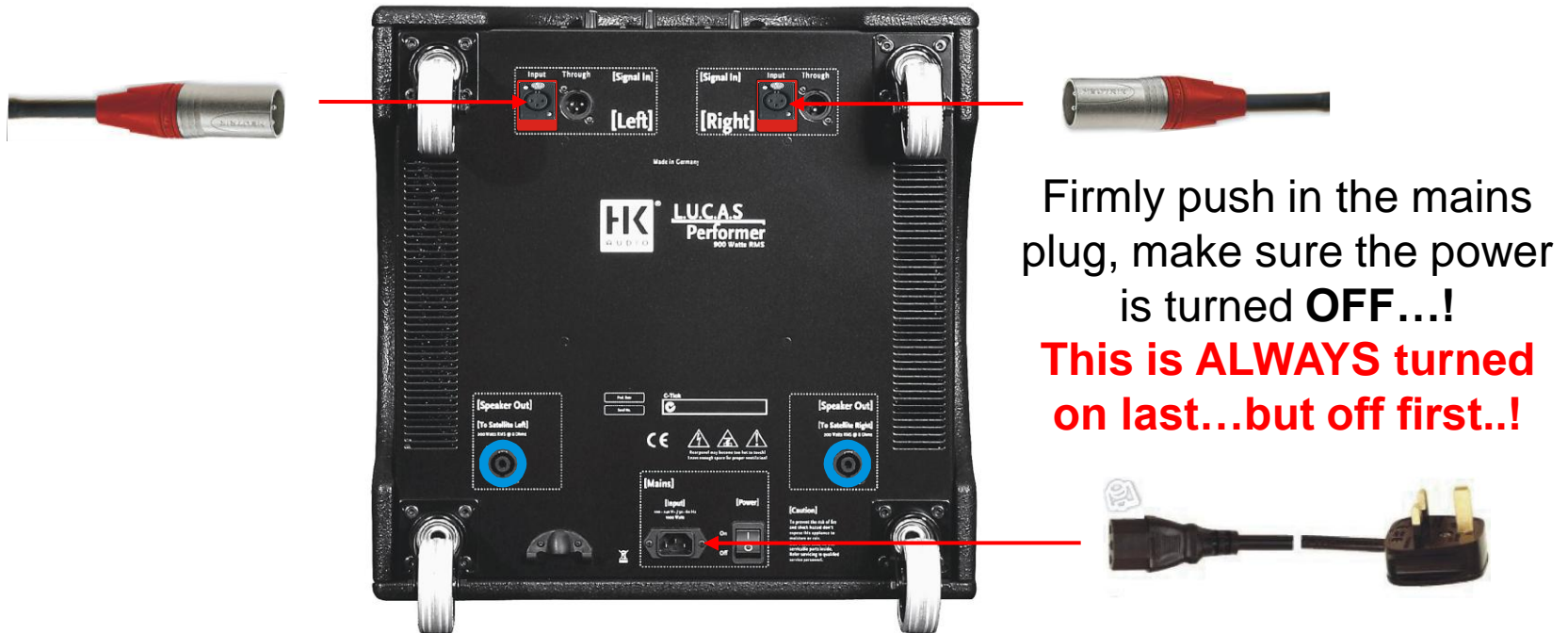

# LUCAS Performer

Connecting the interface to the sub / amplifier.



**Blue** LED to confirm power is on.

Once you have both ends of the **YELLOW** to **RED** leads connected you're ready to hear the system. After checking that ALL leads are connected properly switch on the sub / amplifier which takes 2 – 3 seconds to do self check. Then we recommend that the, "VOL" level is increased to the 12 noon position, then increase the, "IPOD" level to the desired volume.

# LUCAS Performer

Connecting the interface to the sub / amplifier.



## NOTE:

Try to keep the volume level within the **GREEN** (0) lights. Avoid going into the **RED** (CLIP) lights at all costs this can be very harmful to the system

If you would like to use a second IPOD, LAPTOP or CD PLAYER we can supply a second lead which will be controlled by the, "CD" level control. This way you can fade from one device to the other....no gaps..!! Or you could cheat and put together a really good playlist and let it play through... 😊

# LUCAS Performer

## Using the system

Once the system is on and playing you'll see the signal indicator lights come on with the music. At first they come on **GREEN** and as you increase the volume they change to **YELLOW**, if you try to increase beyond that they turn to **RED** this indicates the system is being overdriven and is to be avoided..!



There are three level controls two called, (GAIN LEFT) / (GAIN RIGHT) and one called, (Subwoofer) These are set and left in the 12 noon position.

# LUCAS Performer

## NOTE:

All we ask is please try and avoid drinks being spilt into any of the equipment and of course your IPOD or laptop etc...☹



# LUCAS Performer

## Switching off at the end of the night..

Firstly turn down both the main volume and ipod level to off.



Then switch off the the power on the sub / amplifier and remove the power lead.

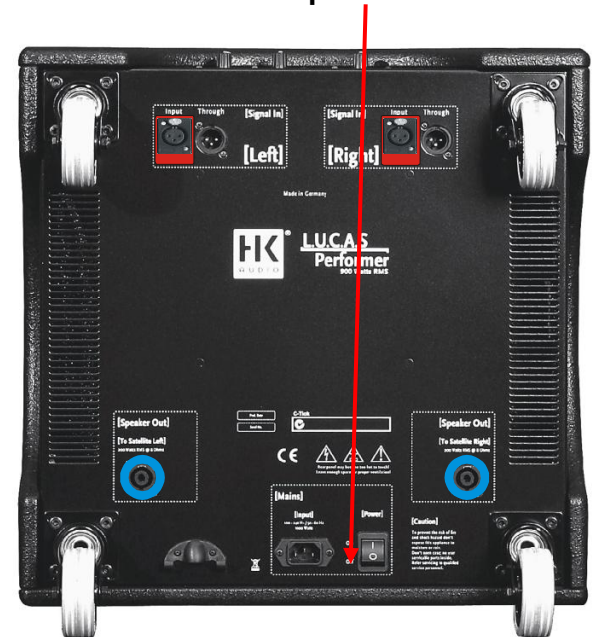

Now you can disconnect all the other leads in any order you like...!

# LUCAS Performer

## Packing everything away...

Please remember to put the three speakers back in their covers, and the speaker stands back into their bag.



# LUCAS Performer

If you could please coil up the leads as below we would appreciate it.. 😊



The interface, ipod lead/s and **YELLOW** to **RED** leads are stored in a little carry case..